

PBS TURBINE ENGINE PORTFOLIO

COMPLETE IN-HOUSE DESIGN & PRODUCTION

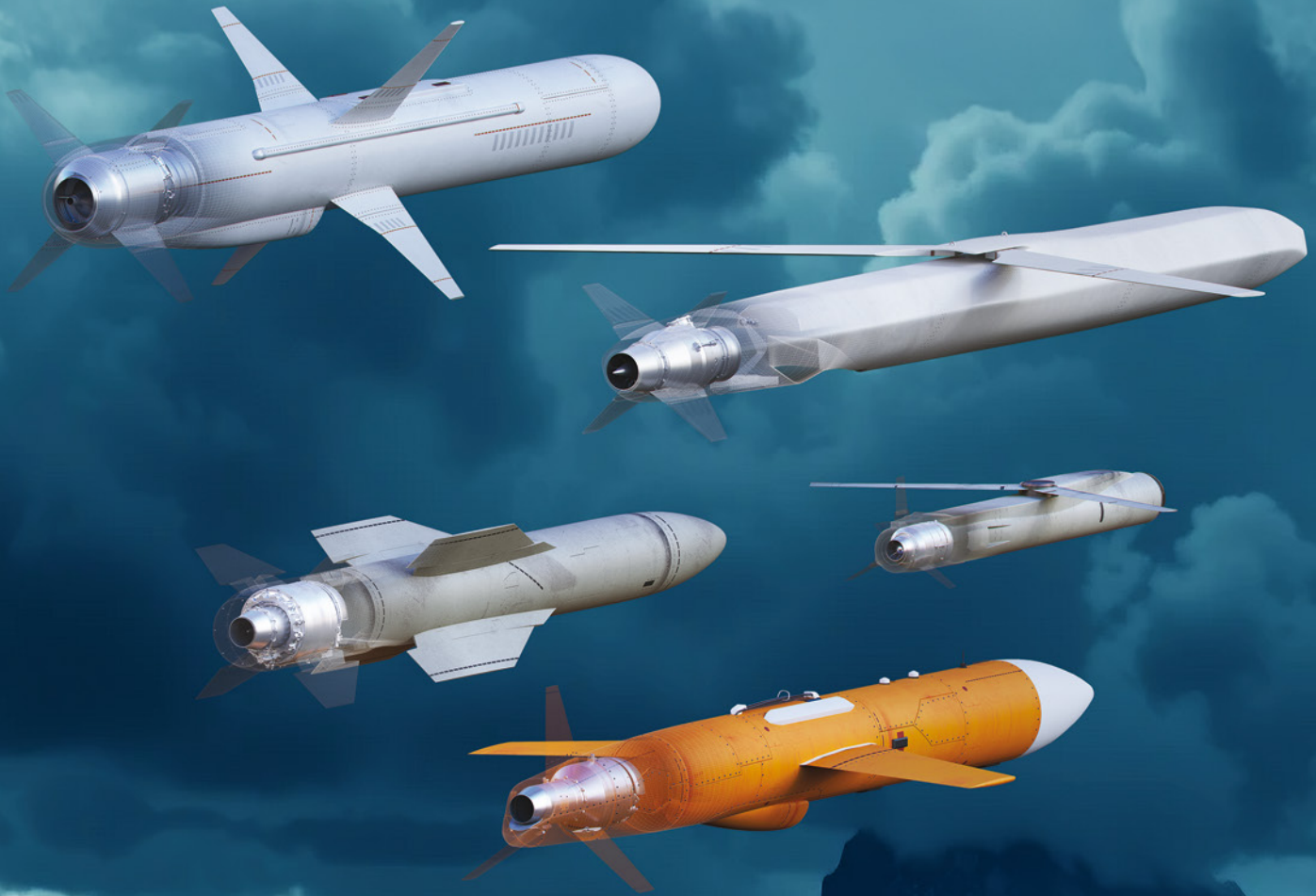

PBS
AEROSPACE

www.pbsaerospace.com

About us

PBS GROUP is an international engineering company with over 200 years of heritage in precision manufacturing. We combine expertise across multiple industries through our subsidiaries, specializing in aerospace technology, precision casting, energy solutions, and cryogenic applications. Our comprehensive portfolio includes the development and manufacture of aircraft engines, auxiliary power units (APU), environmental control systems (ECS), and advanced cryogenic equipment.



One-Stop-Shop Company

We provide complete solutions through our extensive in-house capabilities. From initial design and R&D through to production and testing, we maintain control of 90% of our manufacturing processes. Our modern testing facilities, combined with customized solutions and flexible customer service, ensure comprehensive product lifecycle support. Through our subsidiaries, we offer integrated solutions that meet the highest standards of precision engineering and manufacturing excellence.

PBS AEROSPACE



Customer Support and Services

We offer a comprehensive range of customer support and services based on our extensive experience. Our technical support includes technician training programme, which can be held either at the PBS facility or at the customer's site.

We also provide detailed service and product documentation with regular updates, online technical support and on-site assistance to ensure seamless operation and customer satisfaction.

Why us?

Our excellence is validated through international certifications including ISO 9001, AS9100, ISO 14001, and Nadcap. We are proud that our turbojet engines rank among the world's finest in their category, while our APUs and ECS units serve thousands of aircraft globally. As a key player in both aerospace and cryogenic equipment, we deliver innovative solutions to leading manufacturers worldwide.

PBS Velká Bíteš
PBS International Trading
PBS ENERGO

PBS INDIA

Where We Operate

Our business

- ▶ Aerospace
- ▶ Investment Casting
- ▶ Cryogenics
- ▶ Power Engineering
- ▶ Surface Treatments

Certification





High-Quality Service Infrastructure and Technical Support

The development and production of UAV turbine engines at PBS is also supported by our own extensive in-house testing facility. More than 50 experienced flight test engineers and technicians have a total of 16 specialized testing cells at their disposal for comprehensive testing of turbine engines as well as auxiliary power units and environmental control systems.

Test Capabilities

- ✓ Turbojet engines with a thrust of up to 2,500 N
- ✓ Flight speed simulations of up to 0.8 M
- ✓ Testing with an air pressure of up to 1,200 kPa
- ✓ Temperatures from -60 to 80 °C
- ✓ G-force limit tests
- ✓ Vibration and impact tests
- ✓ Complete ATP and production testing

PBS TJ200



Technical Parameters

PARAMETERS	METRIC	IMPERIAL
Thrust	2,280 N	512.54 lbf
Power supply	28 V DC	28 V DC
El. power output	4.0 kW	4.0 kW
SFC	0.130 kg/N/h	1.275 lb/lbf/hr
TBO	Up to 25 hrs	Up to 25 hrs

DIMENSIONS	METRIC	IMPERIAL
Outer diameter*	246 mm	9.68 in
Length	730 mm	28.74 in
Weight	28.0 kg	61.73 lb

OPERATING ENVELOPE	METRIC	IMPERIAL
Max. altitude	10,000 m	32,808 ft
Max. speed	0.9 M	0.9 M
Ambient temp.	-50/+45 °C	-58/+113 °F

STARTING ENVELOPE	METRIC	IMPERIAL
Max. altitude	6,000 m	19,685 ft
Max. speed	0.4 to 0.6 M	0.4 to 0.6 M
Ambient temp.	-35/+45 °C	-31/+113 °F

*Excluding insulation and equipment

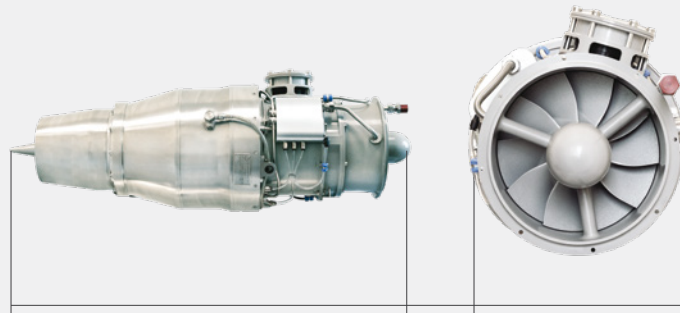

730 mm | 28.74 in

246 mm | 9.68 in



MODIFICATION



APPLICATIONS

→ **2,280 N**

 **28.0 kg**





PBS TJ150



MODIFICATION



APPLICATIONS

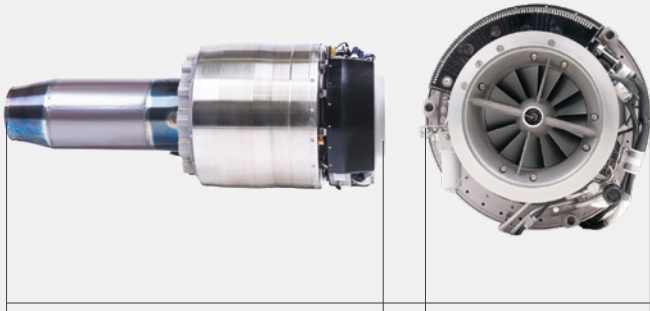

636 mm | 25.04 in

272 mm | 10.71 in

Technical Parameters

PARAMETERS	METRIC	IMPERIAL
Thrust	1,500 N	337 lbf
Power supply	28 V DC	28 V DC
El. power output	600 - 2,250 W	600 - 2,250 W
SFC	0.12 kg/N/h	1.138 lb/lbf/hr
TBO	25 - 50 hrs	25 - 50 hrs

DIMENSIONS	METRIC	IMPERIAL
Outer diameter	272 mm	10.71 in
Length	636 mm	25.04 in
Weight	18.10 kg	39.90 lb

OPERATING ENVELOPE	METRIC	IMPERIAL
Max. altitude	10,000 m	32,808 ft
Max. speed	0.9 M	0.9 M
Ambient temp.	-50/+45 °C	-58/+113 °F

STARTING ENVELOPE	METRIC	IMPERIAL
Max. altitude	6,000 m	19,685 ft
Max. speed	0.6 M	0.6 M
Ambient temp.	-35/+45 °C	-31/+113 °F

⇒ **1,500 N**

 **18.10 kg**



PBS TJ100



MODIFICATION

Technical Parameters

PARAMETERS	METRIC	IMPERIAL
Thrust	1,100 - 1,250 N	247 - 281 lbf
Power supply	28 V DC	28 V DC
El. power output	700 - 2,300 W	700 - 2,300 W
SFC	0.118 kg/N/h	1.157 lb/lbf/hr
TBO	25 - 300 hrs	25 - 300 hrs

DIMENSIONS	METRIC	IMPERIAL
Outer diameter	272 mm	10.71 in
Length	636 mm	25.04 in
Weight	17.60 kg	38.80 lb

OPERATING ENVELOPE	METRIC	IMPERIAL
Max. altitude	10,000 m	32,808 ft
Max. speed	0.9 M	0.9 M
Ambient temp.	-50/+45 °C	-58/+113 °F

STARTING ENVELOPE	METRIC	IMPERIAL
Max. altitude	6,000 m	19,685 ft
Max. speed	0.5 M	0.5 M
Ambient temp.	-35/+45 °C	-31/+113 °F

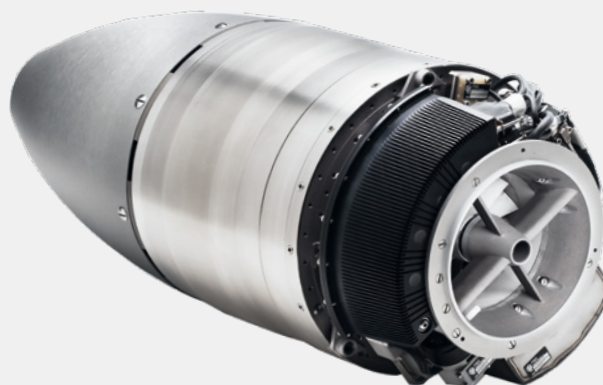

636 mm | 25.04 in

272 mm | 10.71 in



APPLICATIONS

→ 1,250 N

📏 17.60 kg

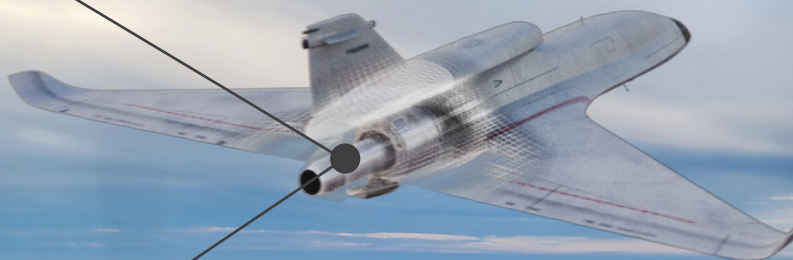



PBS TJ80-120

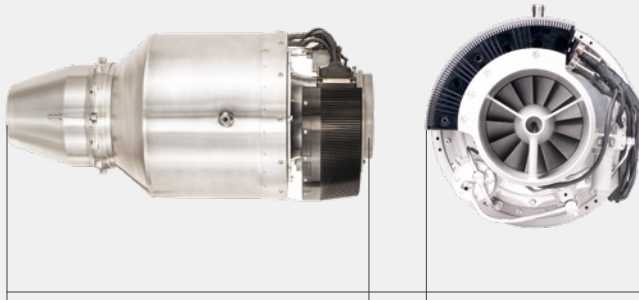

512 mm | 20.16 in

235 mm | 9.25 in

Technical Parameters

PARAMETERS	METRIC	IMPERIAL
Thrust	900 - 1,200 N	202 - 269 lbf
Power supply	28 V DC	28 V DC
El. power output	650 - 2,250 W	650 - 2,250 W
SFC	0.130 kg/N/h	1.275 lb/lbf/hr
TBO	25 hrs	25 hrs

DIMENSIONS	METRIC	IMPERIAL
Outer diameter	235 mm	9.25 in
Length	512 mm	20.16 in
Weight	13.00 kg	28.66 lb

OPERATING ENVELOPE	METRIC	IMPERIAL
Max. altitude	10,000 m	32,808 ft
Max. speed	0.9 M	0.9 M
Ambient temp.	-50/+45 °C	-58/+113 °F

STARTING ENVELOPE	METRIC	IMPERIAL
Max. altitude	6,000 m	19,685 ft
Max. speed	0.6 M	0.6 M
Ambient temp.	-35/+45 °C	-31/+113 °F



APPLICATIONS

⇒ 1,200 N

📏 13.00 kg



PBS TJ40-G1



MODIFICATION

Technical Parameters

PARAMETERS	METRIC	IMPERIAL
Thrust	395 - 425 N	89 - 96 lbf
Power supply	14 - 28 V DC	14 - 28 V DC
El. power output	150 - 250 W	150 - 250 W
SFC	0.153 kg/N/h	1.500 lb/lbf/hr
TBO	50 hrs	50 hrs

DIMENSIONS	METRIC	IMPERIAL
Outer diameter	147 mm	5.79 in
Length	304 mm	11.97 in
Weight	3.40 kg	7.50 lb

OPERATING ENVELOPE	METRIC	IMPERIAL
Max. altitude	9,000 m	29,528 ft
Max. speed	0.8 M	0.8 M
Ambient temp.	-50/+50 °C	-58/+122 °F

STARTING ENVELOPE	METRIC	IMPERIAL
Max. altitude	4,500 m	14,764 ft
Max. speed	0.35 M	0.35 M
Ambient temp.	-40/+50 °C	-40/+122 °F

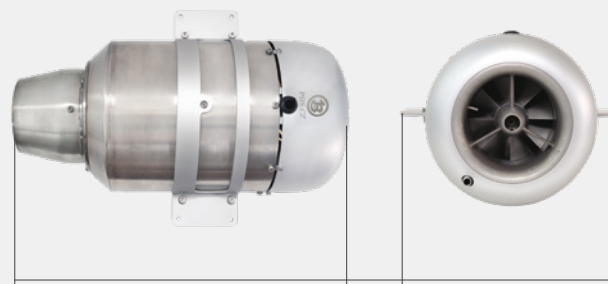

304 mm | 11.97 in

147 mm | 5.79 in



APPLICATIONS

→ 425 N

📏 3.40 kg





PBS TJ40-G1NS



MODIFICATION



APPLICATIONS

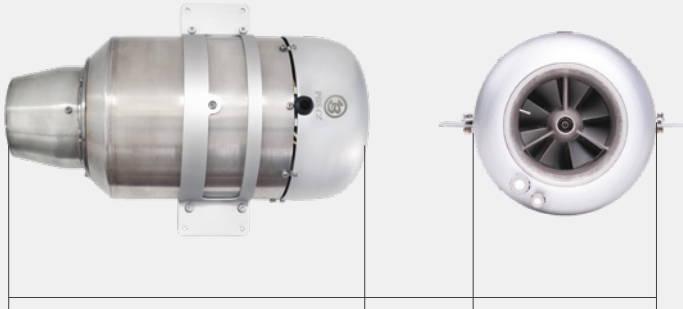

304 mm | 11.97 in

147 mm | 5.79 in

Technical Parameters

PARAMETERS	METRIC	IMPERIAL
Thrust	395 - 425 N	89 - 96 lbf
Power supply	14 V DC	14 V DC
El. power output	150 W	150 W
SFC	0.153 kg/N/h	1.500 lb/lbf/hr
TBO	30 hrs	30 hrs

DIMENSIONS	METRIC	IMPERIAL
Outer diameter	147 mm	5.79 in
Length	304 mm	11.97 in
Weight	3.60 kg	7.93 lb

OPERATING ENVELOPE	METRIC	IMPERIAL
Max. altitude	9,000 m	29,528 ft
Max. speed	0.8 M	0.8 M
Ambient temp.	-50/+50 °C	-58/+122 °F

STARTING ENVELOPE	METRIC	IMPERIAL
Max. altitude	4,500 m	14,764 ft
Max. speed	0.15 M	0.15 M
Ambient temp.	-40/+50 °C	-40/+122 °F

→ 425 N

📏 3.60 kg



PBS TJ40-G2



Technical Parameters

PARAMETERS	METRIC	IMPERIAL
Thrust	395 - 425 N	89 - 96 lbf
Power supply	28 V DC	28 V DC
El. power output	300 - 1,200 W	300 - 1,200 W
SFC	0.153 kg/N/h	1.500 lb/lbf/hr
TBO	50 hrs	50 hrs

DIMENSIONS	METRIC	IMPERIAL
Outer diameter	147 mm	5.79 in
Length	373 mm	14.68 in
Weight	3.80 kg	8.37 lb

OPERATING ENVELOPE	METRIC	IMPERIAL
Max. altitude	9,000 m	29,528 ft
Max. speed	0.9 M	0.9 M
Ambient temp.	-50/+50 °C	-58/+122 °F

STARTING ENVELOPE	METRIC	IMPERIAL
Max. altitude	4,500 m	14,764 ft
Max. speed	0.35 M	0.35 M
Ambient temp.	-40/+50 °C	-40/+122 °F

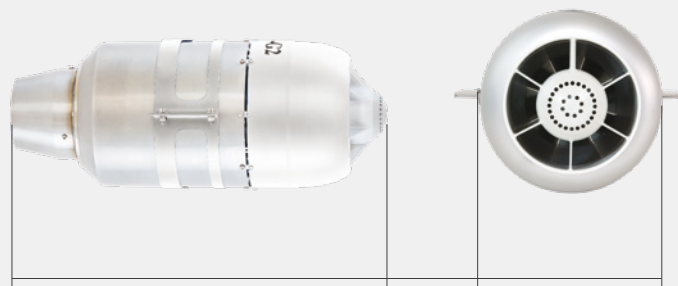

373 mm | 14.68 in

147 mm | 5.79 in



APPLICATIONS

→ **425 N**

 **3.80 kg**

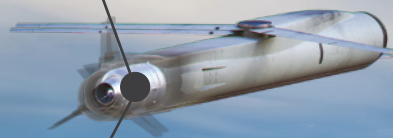



PBS TP100 TURBOPROP ENGINE



MODIFICATION



APPLICATIONS



330 mm | 13.00 in

891 mm | 35.08 in

Technical Parameters

PARAMETERS	METRIC	IMPERIAL
Output shaft speed	2,158 RPM	2,158 RPM
Power supply	28 V DC	28 V DC
El. power output	720 - 3,700 W	720 - 3,700 W
Max. output power	180 kW	241 HP
Specific fuel consumption	0.548 kg/kW/h	0.901 lb/HP/hr

DIMENSIONS	METRIC	IMPERIAL
Height x width (no exhaust)	398 x 330 mm	15.67 x 13.00 in
Length	891 mm	35.08 in
Weight	61.60 kg	135.80 lb

OPERATING ENVELOPE	METRIC	IMPERIAL
Max. altitude	9,000 m	29,528 ft
Ambient temp.	-50/+45 °C	-58/+113 °F

STARTING ENVELOPE	METRIC	IMPERIAL
Max. altitude	6,000 m	19,685 ft
Ambient temp.	-30/+45 °C	-22/+113 °F



PBS TS100

TURBOSHAFT ENGINE



MODIFICATION



APPLICATIONS

Technical Parameters

PARAMETERS	METRIC	IMPERIAL
Output shaft speed	5,978/2,158 RPM	5,978/2,158 RPM
Power supply	28 V DC	28 V DC
El. power output	720 - 3,700 W	720 - 3,700 W
Max. output power	180 kW	241 HP
Specific fuel consumption	0.548 kg/kW/h	0.901 lb/HP/hr

DIMENSIONS	METRIC	IMPERIAL
Height x width (no exhaust)	398 x 330 mm	15.67 x 13.00 in
Length	829/881 mm	32.64/34.69 in
Weight	56.70/61.30 kg	125.00/135.10 lb

OPERATING ENVELOPE	METRIC	IMPERIAL
Max. altitude	9,000 m	29,528 ft
Ambient temp.	-50/+45 °C	-58/+113 °F

STARTING ENVELOPE	METRIC	IMPERIAL
Max. altitude	6,000 m	19,685 ft
Ambient temp.	-30/+45 °C	-22/+113 °F

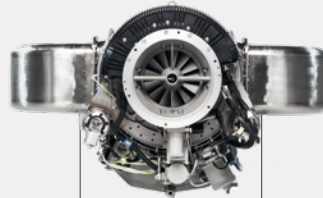

330 mm | 13.00 in

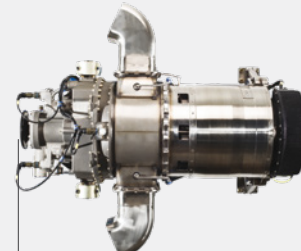

829/881 mm
32.64/34.69 in



ENGINE SPECIFICATIONS

PBS TJ200

PARAMETERS	METRIC	IMPERIAL
Thrust	2,280 N	512.54 lbf
Power supply	28 V DC	28 V DC
El. power output	4.0 kW	4.0 kW
SFC	0.130 kg/N/h	1.275 lb/lbf/hr
TBO	Up to 25 hrs	Up to 25 hrs
DIMENSIONS	METRIC	IMPERIAL
Outer diameter*	246 mm	9.68 in
Length	730 mm	28.74 in
Weight	28.0 kg	61.73 lb

OPERATING ENVELOPE	METRIC	IMPERIAL
Max. altitude	10,000 m	32,808 ft
Max. speed	0.9 M	0.9 M
Ambient temp.	-50/+45 °C	-58/+113 °F

STARTING ENVELOPE	METRIC	IMPERIAL
Max. altitude	6,000 m	19,685 ft
Max. speed	0.4 to 0.6 M	0.4 to 0.6 M
Ambient temp.	-35/+45 °C	-31/+113 °F

*Excluding insulation and equipment

PBS TJ150

METRIC	IMPERIAL
1,500 N	337 lbf
28 V DC	28 V DC
600 - 2,250 W	600 - 2,250 W
0.12 kg/N/h	1.138 lb/lbf/hr
25 - 50 hrs	25 - 50 hrs
METRIC	IMPERIAL
272 mm	10.71 in
636 mm	25.04 in
18.10 kg	39.90 lb

METRIC	IMPERIAL
10,000 m	32,808 ft
0.9 M	0.9 M
-50/+45 °C	-58/+113 °F

METRIC	IMPERIAL
6,000 m	19,685 ft
0.6 M	0.6 M
-35/+45 °C	-31/+113 °F

PBS TJ100

METRIC	IMPERIAL
1,100 - 1,250 N	247 - 281 lbf
28 V DC	28 V DC
700 - 2,300 W	700 - 2,300 W
0.118 kg/N/h	1.157 lb/lbf/hr
25 - 300 hrs	25 - 300 hrs
METRIC	IMPERIAL
272 mm	10.71 in
636 mm	25.04 in
17.60 kg	38.80 lb

METRIC	IMPERIAL
10,000 m	32,808 ft
0.9 M	0.9 M
-50/+45 °C	-58/+113 °F

METRIC	IMPERIAL
6,000 m	19,685 ft
0.5 M	0.5 M
-35/+45 °C	-31/+113 °F

PBS TP100

PARAMETERS	METRIC	IMPERIAL
Output shaft speed	2,158 RPM	2,158 RPM
Power supply	28 V DC	28 V DC
El. power output	720 - 3,700 W	720 - 3,700 W
Max. output power	180 kW	241 HP
Specific fuel consumption	0.548 kg/kW/h	0.901 lb/HP/hr
DIMENSIONS	METRIC	IMPERIAL
Height x width (no exhaust)	398 x 330 mm	15.67 x 13.00 in
Length	891 mm	35.08 in
Weight	61.60 kg	135.80 lb

OPERATING ENVELOPE	METRIC	IMPERIAL
Max. altitude	9,000 m	29,528 ft
Ambient temp.	-50/+45 °C	-58/+113 °F

STARTING ENVELOPE	METRIC	IMPERIAL
Max. altitude	6,000 m	19,685 ft
Ambient temp.	-30/+45 °C	-22/+113 °F

PBS TS100

METRIC	IMPERIAL
5,978/2,158 RPM	5,978/2,158 RPM
28 V DC	28 V DC
720 - 3,700 W	720 - 3,700 W
180 kW	241 HP
0.548 kg/kW/h	0.901 lb/HP/hr
METRIC	IMPERIAL
398 x 330 mm	15.67 x 13.00 in
829/881 mm	32.64/34.69 in
56.70/61.30 kg	125.00/135.10 lb

METRIC	IMPERIAL
9,000 m	29,528 ft
-50/+45 °C	-58/+113 °F

METRIC	IMPERIAL
6,000 m	19,685 ft
-30/+45 °C	-22/+113 °F

PBS TJ80-120

METRIC	IMPERIAL
900 - 1,200 N	202 - 269 lbf
28 V DC	28 V DC
650 - 2,250 W	650 - 2,250 W
0.130 kg/N/h	1.275 lb/lbf/hr
25 hrs	25 hrs
METRIC	IMPERIAL
235 mm	9.25 in
512 mm	20.16 in
13.00 kg	28.66 lb

METRIC	IMPERIAL
10,000 m	32,808 ft
0.9 M	0.9 M
-50/+45 °C	-58/+113 °F

METRIC	IMPERIAL
6,000 m	19,685 ft
0.6 M	0.6 M
-35/+45 °C	-31/+113 °F

PBS TJ40-G1

METRIC	IMPERIAL
395 - 425 N	89 - 96 lbf
14 - 28 V DC	14 - 28 V DC
150 - 250 W	150 - 250 W
0.153 kg/N/h	1.500 lb/lbf/hr
50 hrs	50 hrs
METRIC	IMPERIAL
147 mm	5.79 in
304 mm	11.97 in
3.40 kg	7.50 lb

METRIC	IMPERIAL
9,000 m	29,528 ft
0.8 M	0.8 M
-50/+50 °C	-58/+122 °F

METRIC	IMPERIAL
4,500 m	14,764 ft
0.35 M	0.35 M
-40/+50 °C	-40/+122 °F

PBS TJ40-G1NS

METRIC	IMPERIAL
395 - 425 N	89 - 96 lbf
14 V DC	14 V DC
150 W	150 W
0.153 kg/N/h	1.500 lb/lbf/hr
30 hrs	30 hrs
METRIC	IMPERIAL
147 mm	5.79 in
304 mm	11.97 in
3.60 kg	7.93 lb

METRIC	IMPERIAL
9,000 m	29,528 ft
0.8 M	0.8 M
-50/+50 °C	-58/+122 °F

METRIC	IMPERIAL
4,500 m	14,764 ft
0.15 M	0.15 M
-40/+50 °C	-40/+122 °F

PBS TJ40-G2

METRIC	IMPERIAL
395 - 425 N	89 - 96 lbf
28 V DC	28 V DC
300 - 1,200 W	300 - 1,200 W
0.153 kg/N/h	1.500 lb/lbf/hr
50 hrs	50 hrs
METRIC	IMPERIAL
147 mm	5.79 in
373 mm	14.68 in
3.80 kg	8.37 lb

METRIC	IMPERIAL
9,000 m	29,528 ft
0.9 M	0.9 M
-50/+50 °C	-58/+122 °F

METRIC	IMPERIAL
4,500 m	14,764 ft
0.35 M	0.35 M
-40/+50 °C	-40/+122 °F

APPLICATIONS



Turboprop
Aircraft



UAV



Helicopter



Missile



Jet
Aircraft

PBS JET ENGINE MODIFICATIONS



OIL
Separate oil system



SALT WATER
Salt water recovery



PYRO
Pyro in-flight ignition



www.pbsaerospace.com



engines@pbs.cz



TE-US02B-2604